

### Product features

- Isolated adjustable power LED driver
- Current adjustment via NFC
- Constant lumen output(CLO)
- Supports i-Data function
- Output current 300...1050 mA
- Max. output power 42 W
- DC emergency
- Flicker-free, dimming range 1%...100% (amplitude dimming)
- Current output default value 100%
- For luminaires with protection class I, II

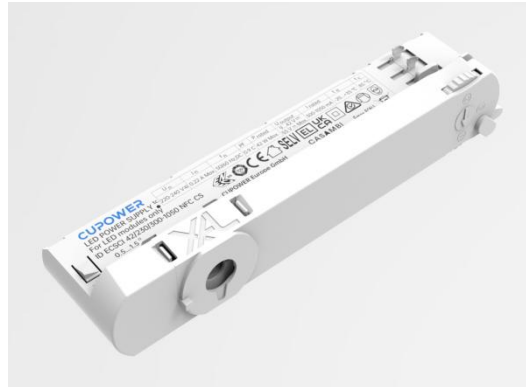

### Product specifications

#### 167036 ID ECSCI 42/230/300-1050 NFC CS

Output current	Input voltage	Output voltage	Efficiency @full load	Current accuracy	Power factor @full load	Dimension LxWxH (mm)
300...1050 mA	220...240 Vac 220...240 Vdc	9...42 Vdc	88% ( @ 40 V 1050 mA)	± 5%	0.9 (Output Power >15 W @ 230 Vac 50 Hz)	182 x 42 x 31

### Electrical specifications

#### Mains voltage supply

Rated input voltage range	220...240 Vac
Max. input voltage range	198...264 Vac
Rated frequency range	0/50/60 Hz
Max. input current	0.22 A @ 230 Vac & 0.22 A @ 230 Vdc

#### Battery operation

DC voltage range	220...240 Vdc
Max. DC voltage range	176...280 Vdc

#### Protection against voltage peaks

Withstand voltage	I/p-O/p: 3 kVac, < 5 mA 60 sec, I/p-Da: 1.5 kVac, < 5 mA 60 sec, O/p-Da: 1.5 kVac, < 5 mA 60 sec
Mains surge immunity	L-N 1 kV

#### Total harmonic distortion (THD)

At rated input voltage range @ full load	10%
--	-----

## Output data

Output current tolerance	± 5% at rated input voltage range
No load output voltage	≤ 55 Vdc
Ripple output current	5% (ripple = peak/average total 100 Hz)
Output PstLM	≤ 1 at full load @ rated input voltage
Output SVM	≤ 0.4 at full load @ rated input voltage
DC emergency level	Bluetooth mesh current output decreased to 15% (programmable)

## Protection functions output side

Overvoltage protection	The output voltage is less than or equal to 55 V
Overpower protection	The output power is less than or equal to 47 W
Short circuit protection	Protection device will trigger when short circuit and will auto recover after the fault mode is removed.

## Dimming operation and interface

Standby power consumption	≤ 0.4 W
Dimming mode	AM dimming
Dimming method	Bluetooth mesh dimming
Dimming current range	1%...100%

## Connection terminals

Connection terminal type	The output terminal is a 45° push-in terminal
Wire cross section	Output wire: 0.5...1.5 mm <sup>2</sup>
Wire stripping length	8...9 mm

## Degree of protection

Protection rating	IP20
-------------------	------

## Operating data

Output current range	NFC control adjusts the current: 300...1050 mA
Default current	300 mA
Output voltage range	9...42 Vdc

## Circuit breaker / Inrush current

MCB loading quantity	Inrush current I <sub>peak</sub> : 27.5 A		Inrush current T <sub>width</sub> : 135 μs		
	MCB type	B10	C10	B16	C16
	Units	28	37	46	59

## Supplementary instructions

- The luminaire manufacturer is responsible for measuring and verifying the EMI compliance of the complete luminaire, as the level of radio interference will vary depending on the luminaire construction. Especially primary and secondary cable lengths and their routing may have a significant effect on radio interference.
- For the push DIM function, please follow our instructions, which can be downloaded from [www.cupower.com](http://www.cupower.com).
- The recommended NFC communication distance: 5...20 mm.

## Environmental specifications

Operating temperature	-20... +35°C
Storage temperature	-25... +85°C
Working humidity	10%...90%
Store humidity	5%...95%
Lifetime	at Tc 85°C: 50,000 hrs @ 230 Vac
Maximum Tc temperature	85°C

## Safety & EMC compliance

ENEC+CE
/
/
/
/
/
/

CCC
/
/
/
/
/
/

SAA
/
/
/
/
/
/

## Accessories (optional)

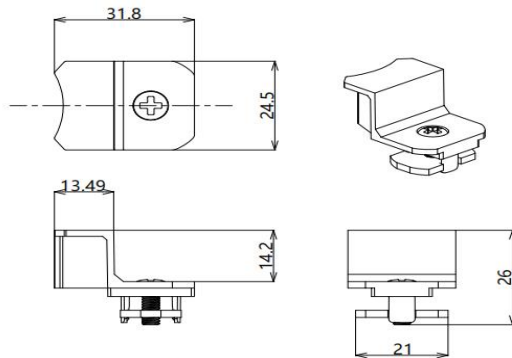

Ratio 1.000

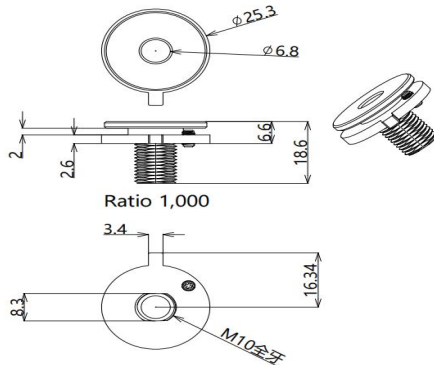

Ratio 1,000

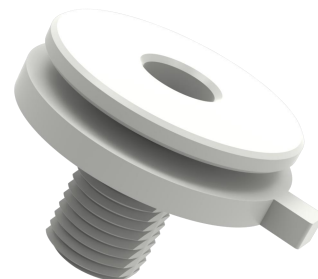

Art.	Dimensions	Length (mm)	Width (mm)	Height (mm)
167630	XZ-TRACK-A	31.8	24.5	26
167678	XZ-TRACK-A1	25.3	25.3	18.6

## Dimensions

### Housing dimensions

Length (L)	182 mm
Width (W)	42 mm
Height (H)	31 mm
Weight	TBD

### Packaging details

Packing units	TBD
Carton size	TBD
Weight	TBD

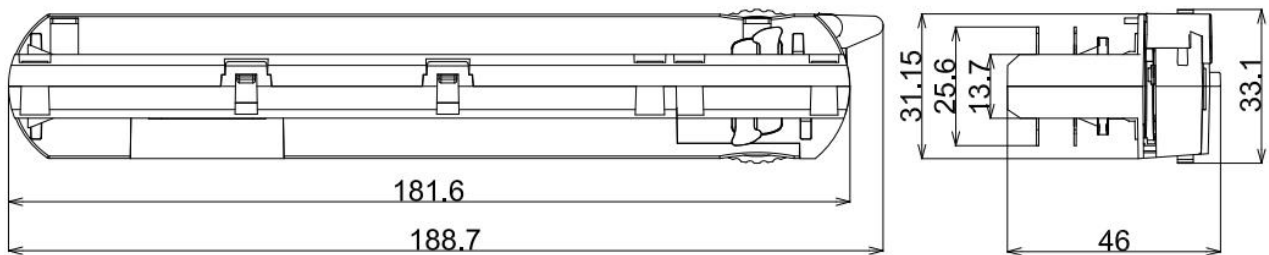
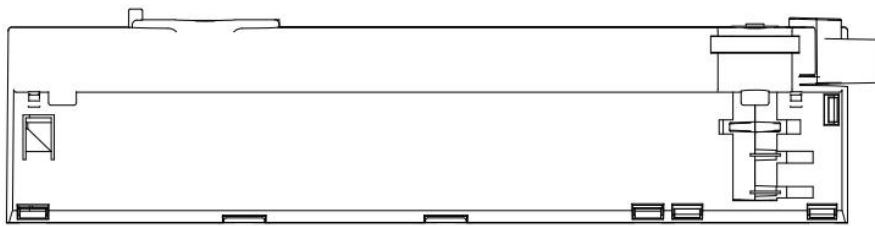

## Wiring diagram

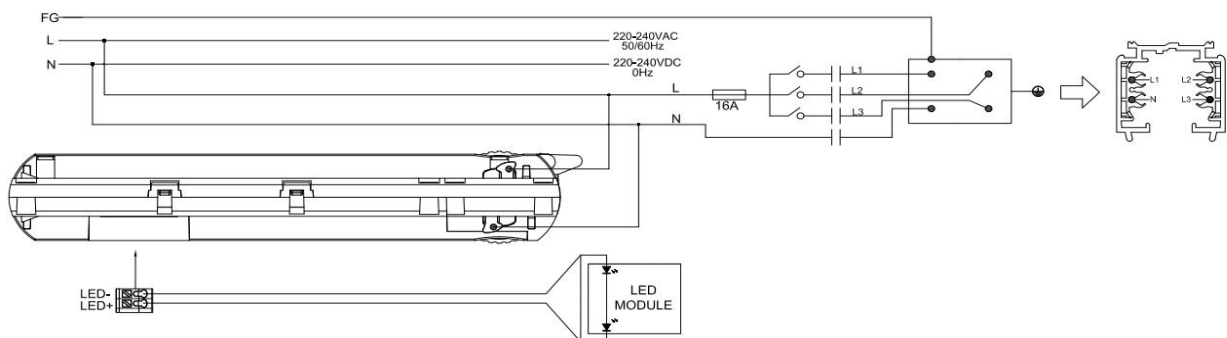

- All connections must be as short as possible to ensure good EMI performance.
- The luminaire wire should keep a certain distance from the LED power supply and other wires (5...10 cm is preferred).
- No secondary switches are allowed.
- Incorrect wiring can damage the LED.
- The wire must be well protected against short circuit.

## Technical information

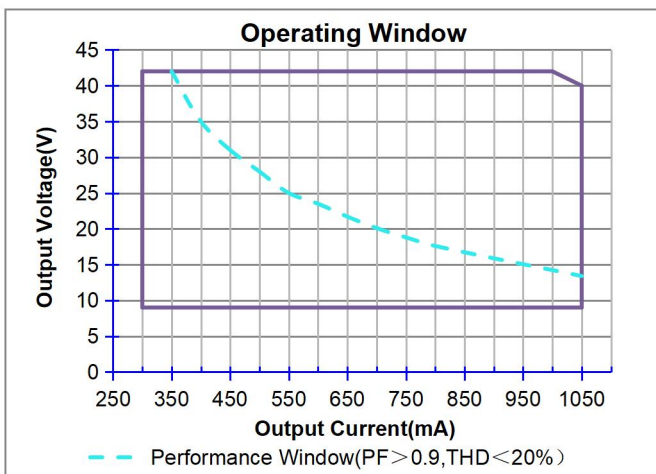
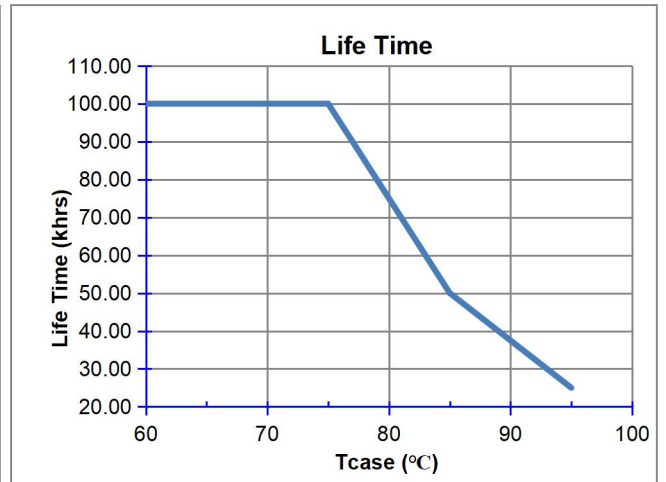
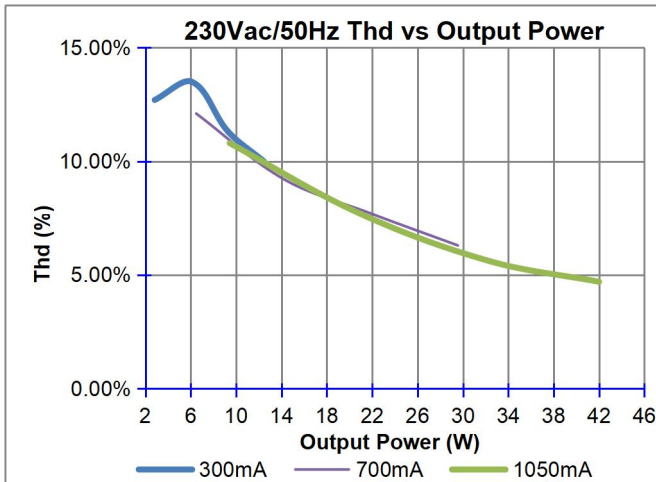
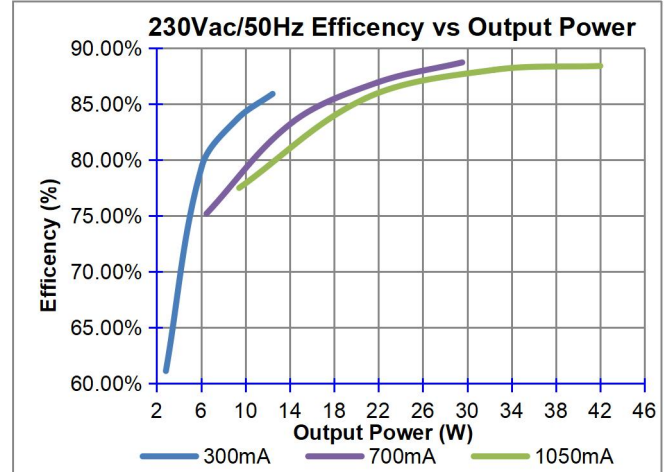
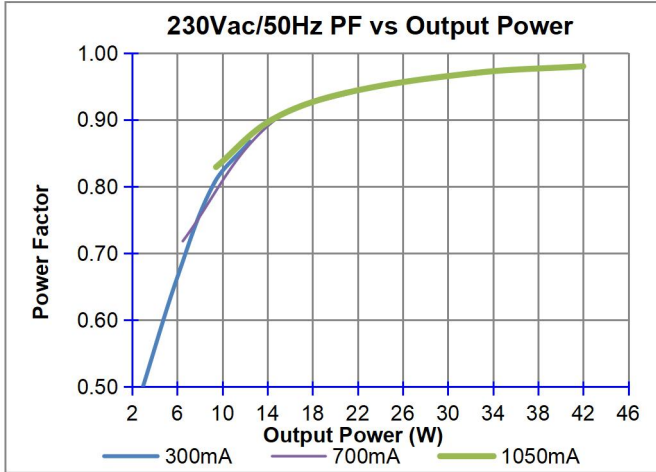

It's important to set the output current (AOC value) according to the LED voltage and make sure the power is within 42 W + 5%.

### Example of AOC settings

V LED (Vdc)	AOC max	Pout (W)
42	1000 mA	42
40	1050 mA	42